

Mechatronic systems



8660-30 C

Stepper motor with integrated driver

- **Low noise**
cool running 1/8 & 1/256 step
- **Dimensions** 57.2 x 57.2 x 93.35 mm
- **Interface** Pulse / Direction / Boost / Enable / Stepselect

This complete drive system is composed of a reliable stepper motor with an integrated driver assembled in a compact housing.

▶ Main features

• **Compact**

A small size and a very low temperature rise are obtained through the integration of a driver in the hybrid bipolar stepper motor.

• **High frequency interface**

The driver allows a high input frequency up to 200 kHz. All inputs have opto-couplers.

• **Low noise**

Thanks to the high resolution of 256 microsteps per step and the driver optimization, the motor rotates with practically no noise and vibration.

• **Very low temperature rise**

The temperature rise is typically 25° C when the motor operates continuously for 2 hours at nominal current (value obtained with the motor screwed on a 150 x 150 x 6 mm aluminium plate). In the same operating conditions, the temperature rise is typically 35° C at boost current.

• **Intelligent driver**

The boost option is particularly useful when a higher torque is required (for example during acceleration / deceleration ramps). The current is automatically reduced to 2/3 of the nominal value at standstill. This feature minimizes the temperature rise.

▶ Technical data

Power supply (+/-20 %)	24 VDC
Maximal input power (Full load, Iboost ON)	65 W
Maximum input frequency	200 kHz
Rotor inertia	425 gcm ²
Detent torque	70 mNm
Holding torque at standstill (reduced current)	720 mNm
Maximum torque at low speed	950 mNm
Weight	982 g
Microsteps per revolution	1600/51200

► Dimensions

Drawing not to scale. All dimensions in mm.

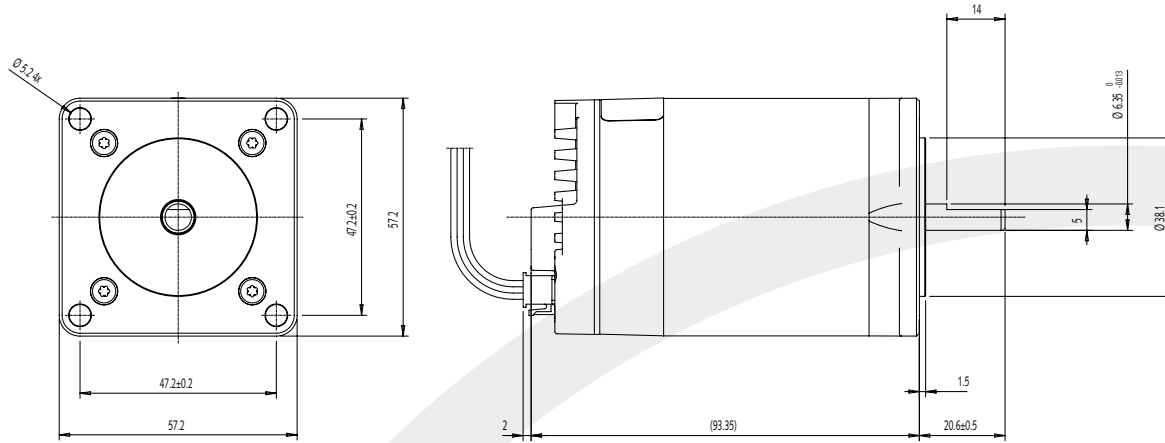

• Dynamic torque

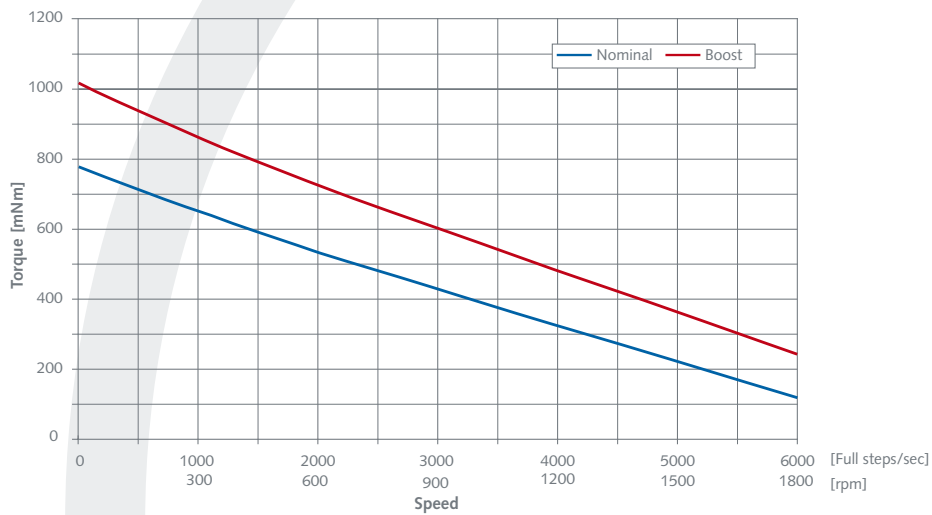

• Max duty cycle vs temperature range

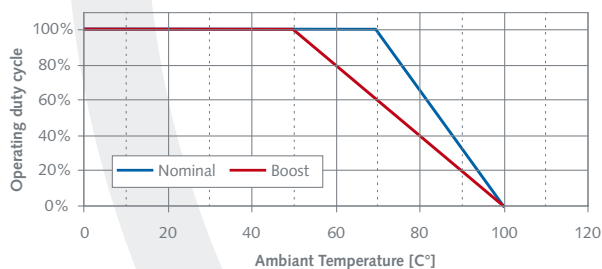

Values obtained with the motor screwed on an aluminum plate (dimensions 150 x 150 x 6 mm)

Special requirements upon customer specifications. Right to change reserved.

< 1.0 >

SONCEBOZ SA
 2605 Sonceboz - Switzerland
 Tel. +41(0) 32 488 11 11
 Fax +41(0) 32 488 11 00
 E-mail : info@sonceboz.com
 Internet : www.sonceboz.com



▶ Electrical Interface

CONNECTOR

• Header MICRO-FIT 3.0 8p

• MOLEX n° 43045 0812



Matching products:

Molex female terminal: 43030 (series)
Molex female housing: 43025 0800

PIN ASSIGNMENTS

- +24 VDC Power supply
- GND Power ground
- Common Ground for logical inputs (Step select, Dir, Enable, Boost, Pulse)
- Pulse Microstep clock input (active on rising edge)

Pin	Description	State 0	State 1
Step select	Microstep resolution	1/8 step (=1600 microsteps / revolution)	1/256 step (= 51200 microsteps / revolution)
Dir	Direction of rotation	CW	CCW
Enable	Power ON	OFF	ON
Boost	Increase in torque	OFF	ON

Note: Step select input is only selectable when Enable = 0 (current OFF)

INPUTS

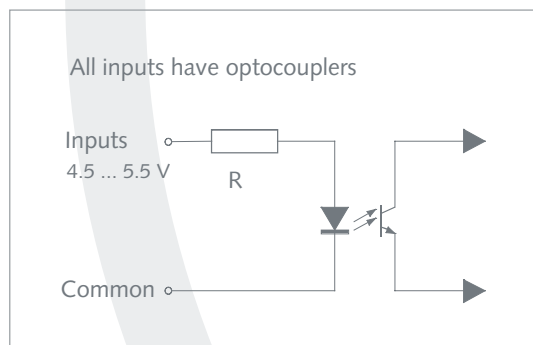

R = 470 Ω, excepted for the pulse input R = 220 Ω.

An external resistor can be added in series with the input to increase the logical voltage up to 24 VDC. For Vin = 24 VDC, the external resistors would be 1.2 kΩ for the pulse and 2.7 kΩ for the others inputs.

Special requirements upon customer specifications. Right to change reserved.

< 1.0 >

CHARACTERISTICS

Characteristics	Symbol	Min	Typ	Max	Unit
Input control voltage low	Vil	0	0	0.8	V
Input control voltage high	Vih	4.5	5	5.5	V
Input current high [Pulse]	lin	12	16	20	mA
Input current high [Dir, Enable, Boost]	lin	6.5	8	9.5	mA
STEP pin low	Tstpl	2.5	-	-	μ s
STEP pin high	Tstph	2.5	-	-	μ s
Setup time for input change to STEP	Tsu	900	-	-	μ s
Hold time for input change from STEP	Th	2.5	-	-	μ s

TIMING DIAGRAM

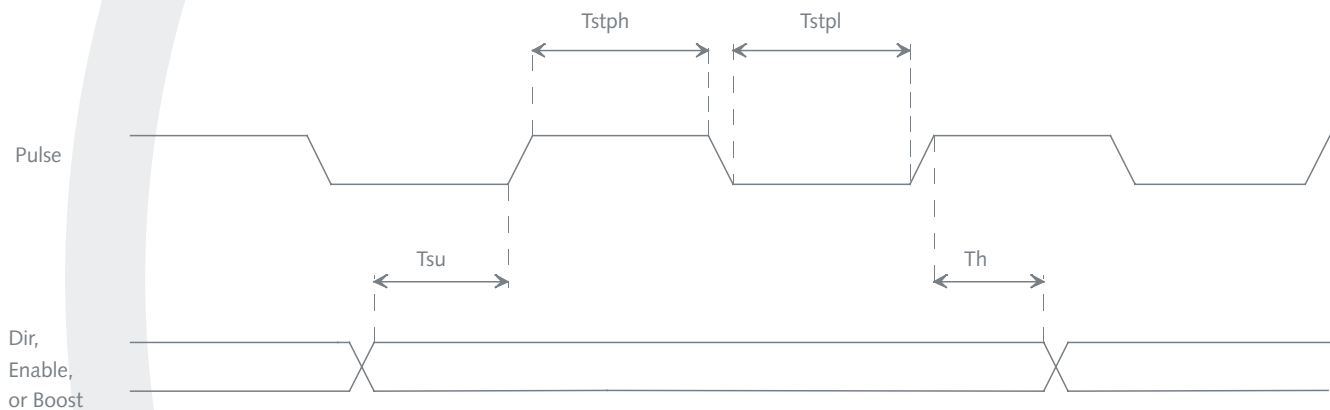

Special requirements upon customer specifications. Right to change reserved.

< 1.0 >

▶ Working conditions

- **Operating temperature range** 0 to 70° C
(Inominal, see graph. Max duty)
- **Protection class** IP50
- **Thermal and over / under voltage protections**

If the motor temperature exceeds 100° C or if the supply voltage comes outside its operating range, the driver is automatically switched off. This is intended to protect components from failure due to excessive temperature or under / over voltage.

To restart the motor after cut off, a rising edge must be applied on the ENABLE input when temperature or voltage error has been cleared. Thermal hysteresis is ~10° C and voltage hysteresis is ~1 V.

▶ Installation

- **Cables and power supply:**

The cables used must have an insulation temperature of at least 105°C. The motor interface must be SELV type (Separated Extra Low Voltage). The cables between the power supply and motor must no be longer than 1 m and a minimal AWG24 diameter must be respected. Every system is delivered with 25 cm connection cable.

- **Temperature and protections:**

Max. temperature of motor and electronic 100°C

It is possible to improve the motor's heat dissipation by fixing it to a metal plate which acts as a heat sink and by using thermoconductive paste. If the motor is accessible or its temperature is high, it may be necessary to fit protecting elements for the safety of the user.

▶ CE marking

- **Electromagnetic compatibility (EMC):**

Directives:

89/336/EEC
+ Modification 92/31/EEC
+ Modification 93/68/EEC

Harmonised standards:

- Electromagnetic emissions in an industrial environment EN 61000-6-4: 2001
- Electromagnetic immunity in an industrial environment EN 61000-6-2: 2001

Special requirements upon customer specifications. Right to change reserved.

< 1.0 >

SONCEBOZ SA
2605 Sonceboz - Switzerland
Tel. +41(0) 32 488 11 11
Fax +41(0) 32 488 11 00
E-mail : info@sonceboz.com
Internet : www.sonceboz.com



▶ Options and adaptations

- Options (minimum quantity required):

- Inputs 24 VDC
- Inputs configuration on request
- Choice of 2 resolutions in the range from full step (1/1) to 1/256 step

- Following adaptations available upon request:

- Communications bus (CAN, RS485, ...)
- Programmable positioning sequences
- Stand-alone operation
- PC programmable
- Mechanical adaptation, connections, etc.

▶ Ordering information

Type	Specific characteristic	Ordering code
8660-30 Low noise cool running	1/8 & 1/256 step, low temperature rise	8660R907