

▶ Hybrid stepper motors

6600-15
automotive

- Step angle 1.8°
- Size Ø 57.4 x 42.2 mm
- Weight 400 g
- Holding torque 400 mNm

The hybrid stepper motor comes into its own where torque at low speed, positioning and accuracy are determining factors. This specific series is specially designed for high temperature and high vibration applications, as automotive, truck and off-road devices.

▶ Technical data

	Part N°	Phase resistance [Ω]	Phase inductance [mH]	Phase current [A]	Holding torque [mNm]	Nominal power [W]
Bipolar	6600-15-2-0.12	0.12	0.20	5.5	400	7.2
	6600-15-2-0.50	0.50	0.90	2.7	400	7.2

Steps/rev.	200
Step accuracy	± 5%
Rotor inertia	131 gcm ²
Insulation class	180 °C
Insulation resistance	>100 MΩ
Test voltage	500 VAC
Detent torque	26 mNm

▶ Dimensions

Drawing not to scale. All dimensions in mm.

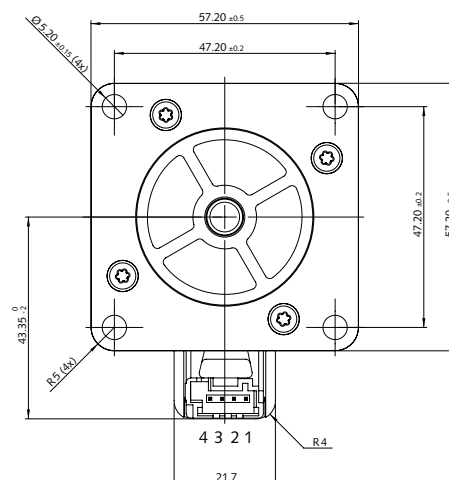
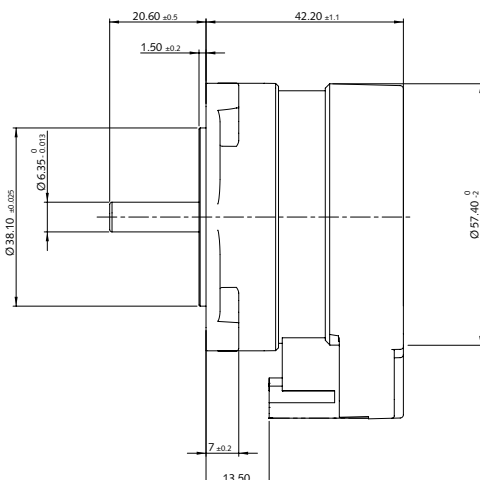

► Dynamic characteristics

• 6600-15-2-0.12

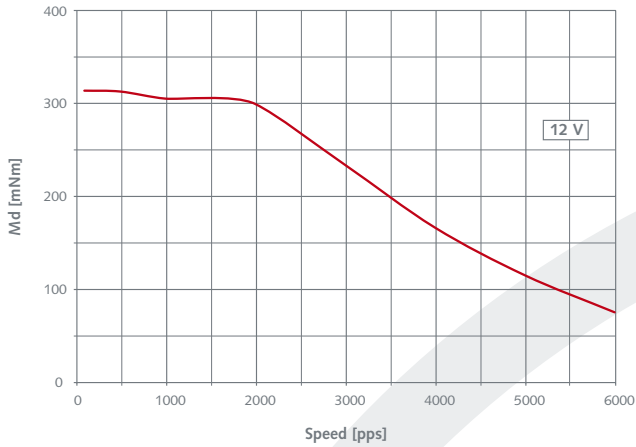

• 6600-15-2-0.50

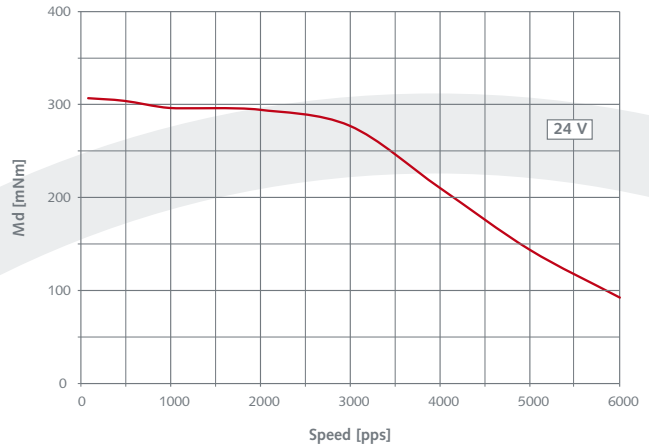

[pps] = pulses per second

► Electrical interface and steps sequence

• Steps sequence

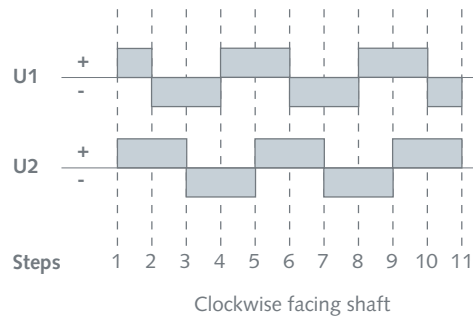
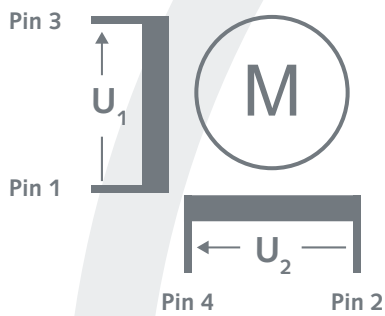

• Connection

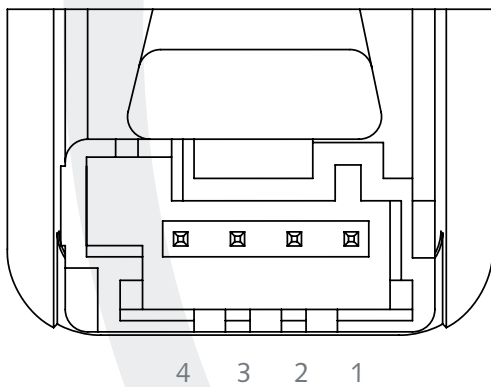

Connector type Tyco AMP MQS C-208-15592
Coding Black

Special requirements upon customer specifications. Right to change reserved.

< 1.1 >