

▶ Brushless - DC motors

5455-30

- Size 57.2 x 57.2 x 76.3 mm
- Continuous output power:
140 W
(270 mNm, 5000 rpm)
- Steps/rev. 30

Dynamic, speed and accuracy are the keywords of BLDC technology. Used when positioning or speed regulation are critical.

▶ Technical data

Weight	1055 g	Motor constant (min. value)	92 mNm/ \sqrt{W}	Torque constant (max. value)	85 mNm/A
Phase number	3-Y	Nominal voltage	60 V	Max, continuous current	6.1 A
Continuous stall torque	520 mNm*	No load speed	6 500 rpm	Terminal inductance	1.12 mH
Max. stall torque	1040 mNm**	Rotor inertia	371 g.cm ²	Protection	IP 30
Detent torque	45 mNm	Terminal resistance	0.64 Ω		

*Continuous values based on 25° C ambient temperature, motor mounted to a 150 x 150 x 10 mm aluminium heat sink.

**Max. 10 sec. at 25° C ambient temperature.

▶ Dimensions

Drawing not to scale. All dimensions in mm.

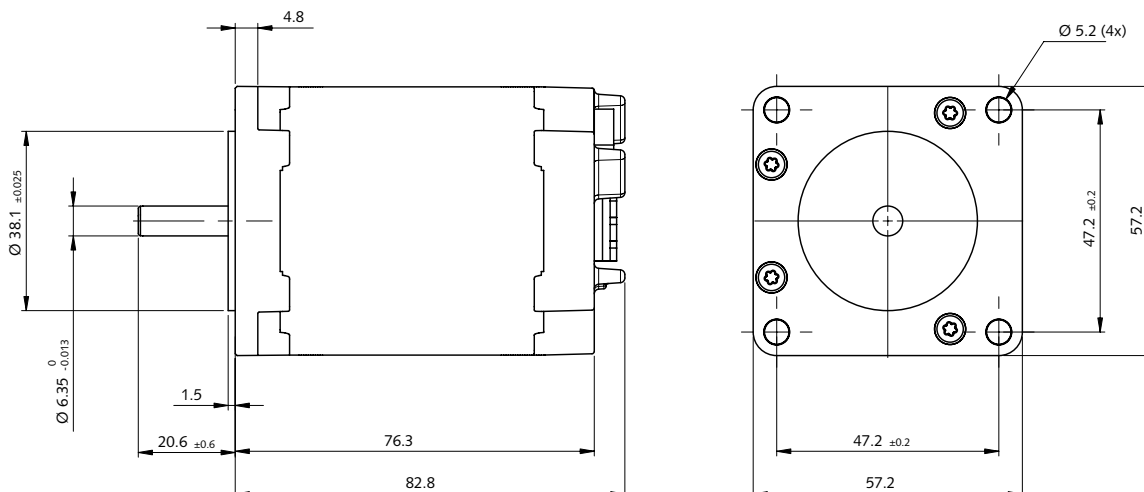

► Dynamic characteristics

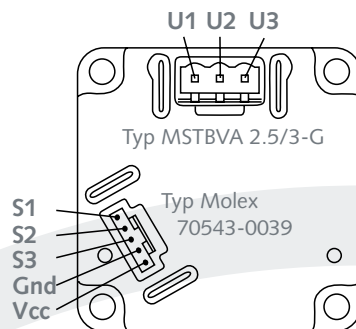
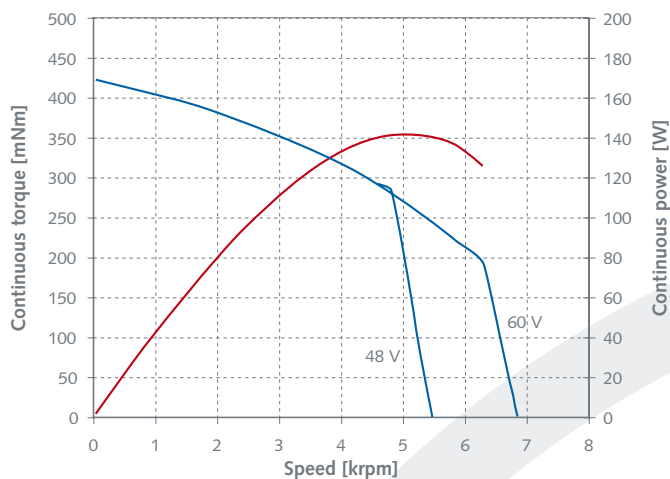

Counter connector (Windings)	MSTB 2.5/3-ST
Counter connector (Hall sensors)	50-57-9405
Tin plate contacts	16-02-0102

• Star connection

• 2 phases on, Fullstep

• Hall sensors signals

Options

- Motors with adapted windings
- Integrated high resolution position sensor
- Driver and control electronics

Special requirements upon customer specifications. Right to change reserved.

< 1.0 >

SONCEBOZ SA
2605 Sonceboz - Switzerland
Tel. +41(0) 32 488 11 11
Fax +41(0) 32 488 11 00
E-mail : info@sonceboz.com
Internet : www.sonceboz.com

